

DESCRIPTION

The SC-651 is a compact, highly intelligible speaker suited to public address announcement applications. Its external speaker component finished with powder coating, and stainless steel screws ensure the unit's weatherproof capability.

SPECIFICATIONS

Rated Input	50 W (Mobile Mount use: 30 W)
Rated Impedance	16 Ω
Sensitivity	109 dB (1 W, 1 m)
Frequency Response	250 – 6,000 Hz
IP Code	IP 65
Polarity	Hot: Black, Com: White
Operating Temperature	-20°C to +55°C (-4°F to 131°F) (must be free from dew condensation)
Finish	Horn flare: Aluminum, off-white, powder coating Reflector horn: ABS resin, off-white Bracket holder: Aluminum, gray, powder coating Bracket: Steel, gray, powder coating Rear cover: ABS resin, gray Screws and bolts: Stainless steel Speaker cable: Polyvinyl chloride insulated cabtyre cable (6 mm (0.24") in diameter, 600 mm (23.62") in length)
Dimensions	430 (W) × 297.5 (H) × 327 (D) mm (16.93" × 11.71" × 12.87")
Weight	3.4 kg (7.5 lb)

APPEARANCE

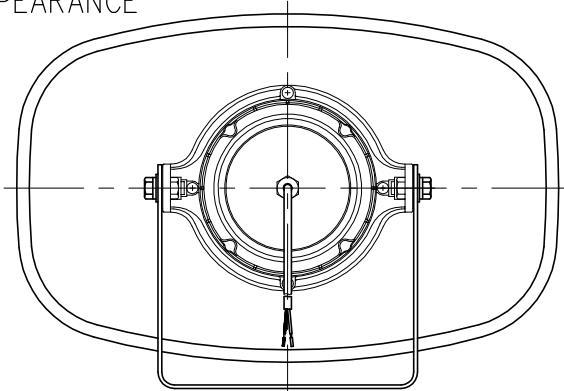

Rear View

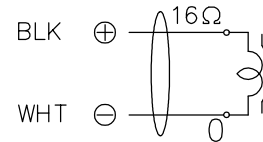

Wiring diagram

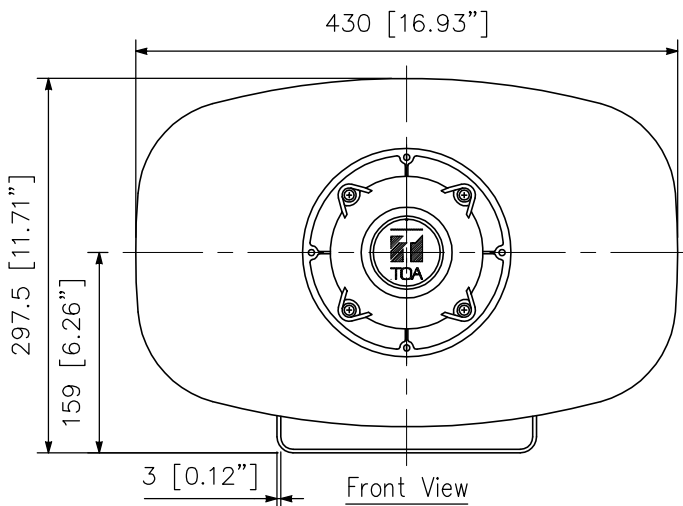

Front View

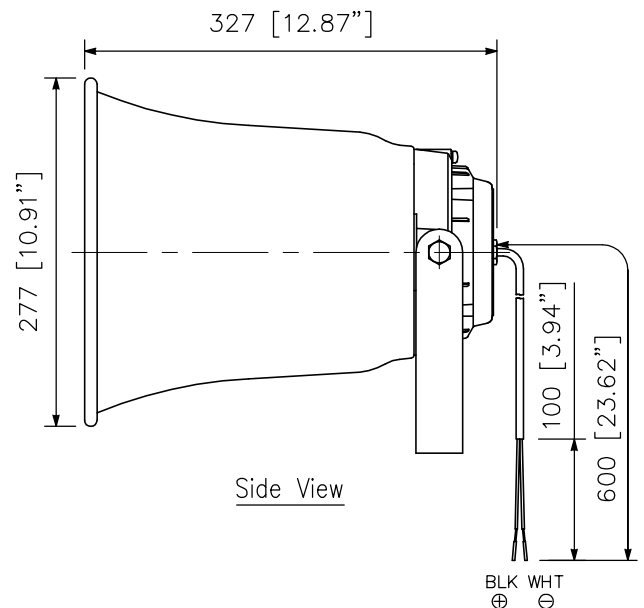

Side View

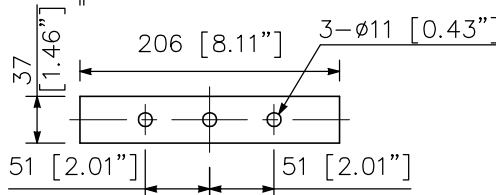

Bracket dimensional diagram

UNIT:mm SCALE:1/6