

120 x 120 x 25mm

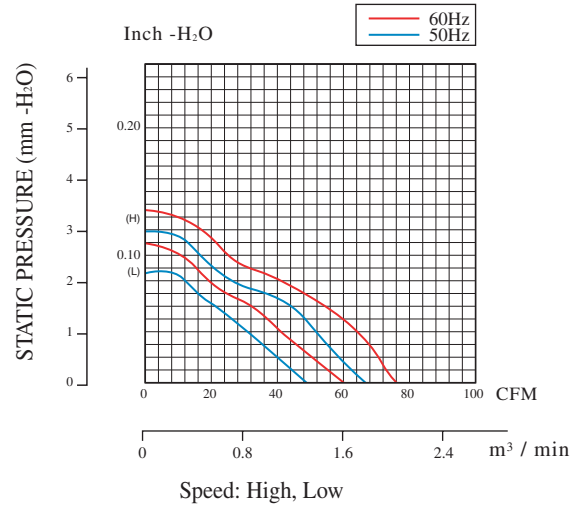
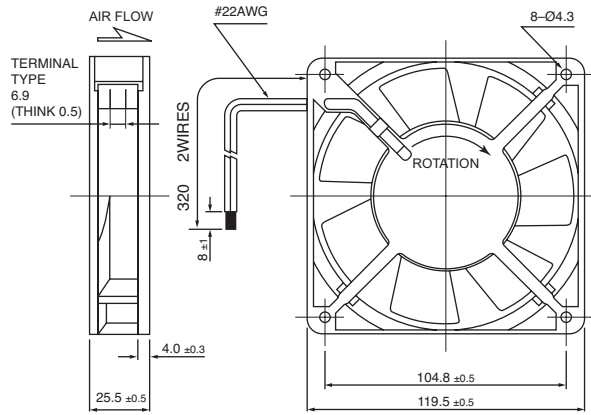

Frame Type: Aluminum painted & Plastic UL94V-O
Impeller: Thermoplastic UL94V-O P.B.T.

Model	Part No. Terminal Leadwire	Bearing System	Rated Voltage (V)	Freq (Hz)	Current (A)	Input Power (W)	Speed (rpm)	Air Flow (CFM)	Static Pressure (mm-H ₂ O)	Noise Level (dB-A)	Weight (g)
(型號)	(端子/出線)	(培林)	(電壓)	(頻率)	(電流)	(功率)	(轉速)	(風量)	(靜壓)	(噪音值)	(重量)
HPE-1225HA1	1225HA1SAT(L) 1225HA1BAT(L)	Sleeve Ball	110/120	50/60	0.13/0.18	11/18	2300/2800	60/76	0.11/0.14	40/44	338
HPE-1225HA2	1225HA2SAT(L) 1225HA2BAT(L)	Sleeve Ball	220/240	50/60	0.07/0.09	14/19	2300/2700	60/76	0.11/0.14	40/44	338
HPE-1225LA1	1225LA1SAT(L) 1225LA1BAT(L)	Sleeve Ball	110/120	50/60	0.08/0.11	7/10	2300/2600	50/60	0.08/0.11	33/37	338
HPE-1225LA2	1225LA2SAT(L) 1225LA2BAT(L)	Sleeve Ball	220/240	50/60	0.05/0.06	10/13	2100/2400	50/50	0.08/0.11	33/37	338

Specifications subject to change without notice.
 以上參考數據，如有變更恕不另行通知。