

80 x 80 x 25mm

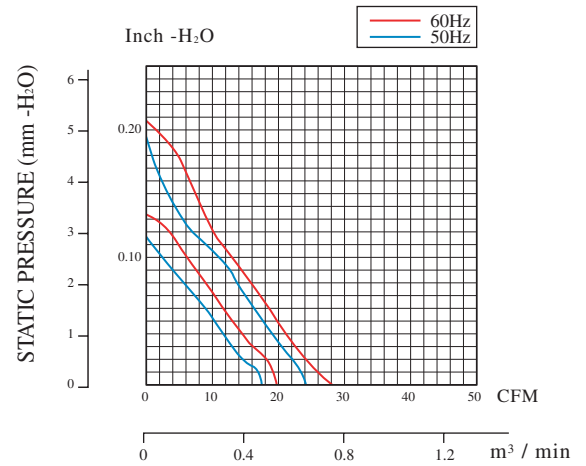
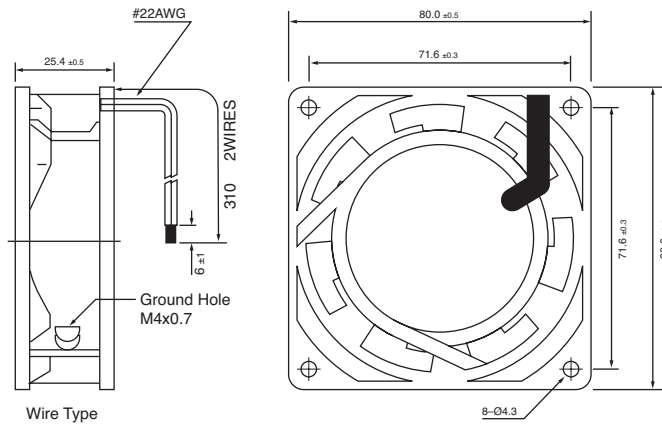

Frame Type: Aluminum painted & Plastic UL94V-O
Impeller: Thermoplastic UL94V-O P.B.T.

Model	Part No. Terminal Leadwire	Bearing System	Rated Voltage	Freq	Current	Input Power	Speed	Air Flow	Static Pressure	Noise Level	Weight
(型號)	(端子/出線)	(培林)	(V)	(Hz)	(A)	(W)	(rpm)	(CFM)	(mm-H ₂ O)	(dB-A)	(g)
			(電壓)	(頻率)	(電流)	(功率)	(轉速)	(風量)	(靜壓)	(噪音值)	(重量)
HPE-80025HA1	80025HA1SAT(L) 80025HA1BAT(L)	Sleeve Ball	110/120	50/60	0.17/0.19	13/14	2400/2800	26/33	0.18/0.21	29/33	200
HPE-80025HA2	80025HA2SAT(L) 80025HA2BAT(L)	Sleeve Ball	220/240	50/60	0.10/0.12	13/14	2400/2800	26/33	0.18/0.21	29/33	200

Specifications subject to change without notice.

以上參考數據，如有變更恕不另行通知。