

W1 Series WDR IP Camera

Full HD • Multiple Streams • Compact

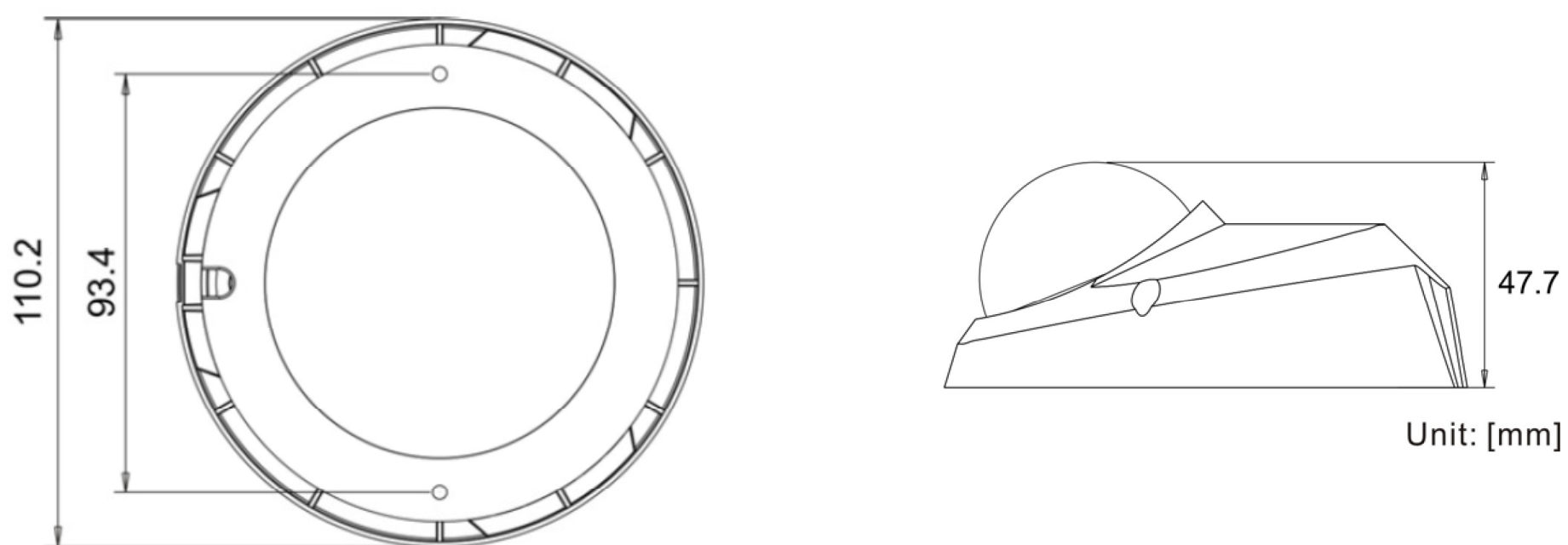

Dimension



Features

- Progressive Scan CMOS Sensor
- Dual Streams, Full HD 1080P real-time + D1 real-time
- H.264 and MJPEG compression
- Multi-language support
- Tampering Alarm
- Wide Dynamic Range
- Motion Detection
- Privacy Masks
- Smart Picture Quality / 3D Noise Reduction
- Weatherproof Dongle Cable*
- Weatherproof (IP66 International)*
- Micro SD support*
- Security Torx against tampering
- ONVIF support

(*) : Items marked with an asterisk (*) are optional

DYNACOLOR
always watching

www.dynacolor.com.hk

W1 Series WDR IP Camera

Specifications

Model	W1-B	W1-A
Camera		
Image Sensor	1/2.7" Progressive Scan CMOS	
Picture Elements	1920(H) x 1080(V)	
Min. Illumination	0.1Lux @ F1.5	
Focal Length	f4.0mm	
Horizontal Angle of View	78°	
Max. Aperture Ratio	F1.5	
Shutter Speed	1 to 1/10,000 sec.	
White Balance	Manual / AWB / ATW	
Digital Zoom	Support	
Lens Mounting	M12	
Operation		
Video Compression	H.264 / MJPEG	
Video Streaming & Frame Rate	Dual Streams: H.264 1080P (25/30fps) + MJPEG D1 (25/30fps) Dual Streams: H.264 1080P (25/30fps) + H.264 D1 (25/30fpd)	Dual Streams: H.264 720P (25/30fps) + MJPEG D1 (25/30fps) Dual Streams: H.264 720P (25/30fps) + H.264 D1 (25/30fpd)
Resolution	Full HD 1080P / SXGA / HD 720P / XGA / SVGA / D1 / VGA / CIF	HD 720P / XGA / SVGA / D1 / VGA / CIF
Image Setting	Exposure, White Balance, Brightness, Sharpness, Contrast, Saturation, Hue, Image Rotation, Motion Detection, Tampering Alarm, Privacy Mask, 3D DNR, Smart Picture Quality	
Built-in Microphone	Optional for Indoor Models	
Event Notification	HTTP, FTP, SMTP	
Network		
Interface	RJ-45, 10/100 Mbps Ethernet	
Protocol	IPv4/V6, TCP/IP, UDP, RTP, RTSP, HTTP, HTTPS, ICMP, FTP, SMTP, DHCP, PPPoE, UPnP, IGMP, SNMP, QoS, IEEE 802.1X, ONVIF	
Security	HTTPS, IP Filter, IEEE 802.1X	
Password Levels	User and Administrator	
Remote Surveillance	CMS	DynaGuard™ CMS*
	Web Browser	Google Chrome, Mozilla Firefox, Internet Explorer9*, Opera & Safari
	Client Software	XGuard for Mac OSX 10.6.6 or later
User Account	20	
Mobile Surveillance	Android, Blackberry, iPhone, Symbian & Windows Mobile	
General		
Micro SD Support	Optional	
Ingress Protection	IP66 (Optional)	
Unit Dimension (W x H x D)	Ø110.2 x 47.7(H) mm	
Unit Weight (Net)	180g	
Operation Temperature	-10 °C ~ 50 °C (14 °F ~ 122 °F)	
Relative Humidity	10% ~ 90%, Non-condensing	
Power Consumption & Input	4W, PoE	
Certificate	CE, FCC, RoHS compliant	

Product specifications and availability are subject to change without notice. Certain product names mentioned herein may be trade names and / or registered trademarks of their companies.

DynaGuard™ CMS System Requirements (Recommended):

Windows 7 Professional, Intel® Core™ 17-2600 (3.4GHz) or faster, 4GB DDR3 RAM, GeForce GTS450 1GB PCI-E 16X Video Card, Gigabit LAN connection

*For Windows Platform Only

DYNACOLOR
always watching

華輝 | 電 | 子 | 科 | 技 |
WECL ELECTRONICS SPECIALIST

A member of Sino Bright Group

華輝無線電行有限公司 Welfare Electronic Component Ltd.
門市部 Retail :
香港九龍深水埗鴨寮街201號明珠樓地下及一樓全層
G/F & 1/F, Ming Chu Building, 201 Apliu Street, Sham Shui Po, Kln, Hong Kong
Tel : (852) 3182 0688 Fax : (852) 3182 0600
E-mail : cs@wecl.com.hk Hotline : (852) 3182 0888

Made in Taiwan

www.dynacolor.com.hk

V1_20120827

☎ 客戶服務熱線:

(852) **3182 0888**

WECLOnline.com
YOUR ELECTRONIC MEGASTORE

