

# W5 Series WDR IP Camera

Full HD • Multiple Streams • Compact

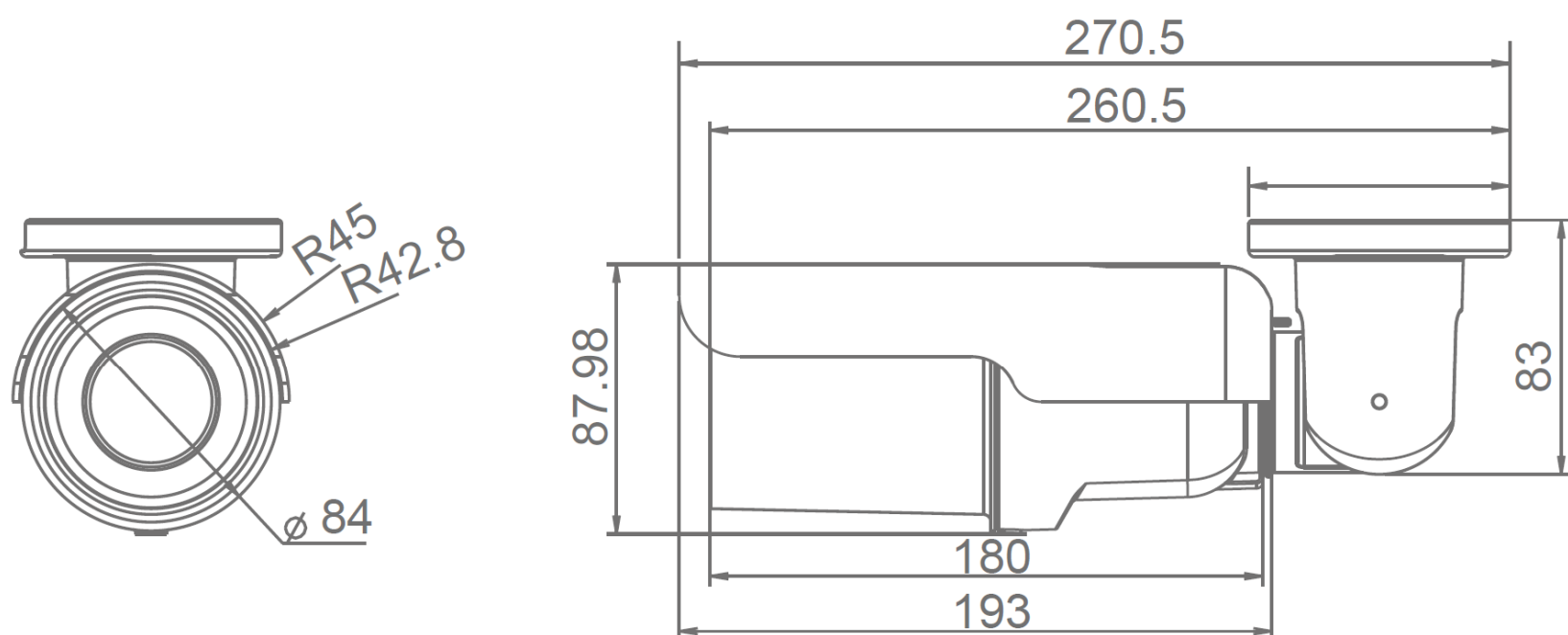

## Dimension



Unit: (mm)

## Features

- Progressive Scan CMOS Sensor
- Dual Streams, Full HD 1080P real-time + D1 real-time
- H.264 and MJPEG compression
- Multi-language support
- Tampering Alarm
- Wide Dynamic Range
- Remote Zoom & Focus (for Motorized Lens only)\*
- Motion Detection & Privacy Masks
- Smart Picture Quality / 3D Noise Reduction
- True Day/Night (w/ ICR)\*
- IR LED module (Effective distance up to 30m)
- Micro SD support
- Weatherproof (IP66 international)
- Integrated Mounting Bracket with Cable Management
- ONVIF support

(\*) : Items marked with an asterisk (\*) are optional

**DYNACOLOR**  
always watching

[www.dynacolor.com.hk](http://www.dynacolor.com.hk)

# W5 Series WDR IP Camera

## Specifications

Model	W5-B	W5-A
<b>Camera</b>		
Image Sensor	1/2.7" Progressive Scan CMOS	
Picture Elements	1920(H) x 1080(V)	
Min. Illumination	0.2Lux@F1.5 (Color) / 0.02Lux@F1.5 (B/W)	
Focal Length	f3 - 9mm	
Horizontal Angle of View	103.5° - 34.3°	
Max. Aperture Ratio	F1.2	
Shutter Speed	1 - 1/10,000 sec.	
White Balance	Manual / AWB / ATW	
Digital Zoom	Support	
Motorized / Manual Vari-focal	Optional	
<b>Operation</b>		
Video Compression	H.264 / MJPEG	
Video Streaming & Frame Rate	Dual Streams: H.264 1080P (25/30fps) + MJPEG D1 (25/30fps) Dual Streams: H.264 1080P (25/30fps) + H.264 D1 (25/30fps)	Dual Streams: H.264 720P (25/30fps) + MJPEG D1 (25/30fps) Dual Streams: H.264 720P (25/30fps) + H.264 D1 (25/30fps)
Resolution	Full HD 1080P25/30 / SXGA / HD 720P / XGA / SVGA / D1 / VGA / CIF	Full HD 1080P12/15 / SXGA / HD 720P / XGA / SVGA / D1 / VGA / CIF
Image Setting	Exposure, White Balance, Brightness, Sharpness, Contrast, Saturation, Hue, Image Rotation, Motion Detection, Tampering Alarm, Privacy Mask, 3D DNR, Smart Picture Quality	
ICR Filter	Optional for Motorized VF Lens	
WDR	On / Off	
Analog Video Output	1.0 Vp-p / 75Ω, BNC	
Two-way Audio	Line out, Female Stereo phone jack Ø3.5mm ; Line in / Mic. in, Female Stereo phone jack Ø3.5mm	
Audio Compression	G.711 / G.726	
Alarm	Input	5V 10kΩ pull up, 4-pin alarm wires
	Output	Photo Relay Output 300VDC/AC, 4-pin alarm wires
Event Notification	HTTP, FTP, SMTP	
Multiple Languages	English, French, German, Italian, Korean, Simplified Chinese, Traditional Chinese, Russian	
<b>Network</b>		
Interface	10/100 Mbps Ethernet, RJ45	
Protocol	IPv4/V6, TCP/IP, UDP, RTP, RTSP, HTTP, HTTPS, ICMP, FTP, SMTP, DHCP, PPPoE, UPnP, IGMP, SNMP, QoS, IEEE 802.1X, ONVIF	
Security	HTTPS, IP Filter, IEEE 802.1X	
Password Levels	User and Administrator	
Remote Surveillance	CMS	DynaGuard™ CMS*
	Web Browser	Google Chrome, Mozilla Firefox, Internet Explorer9*, Opera & Safari
	Client Software	XGuard for Mac OSX 10.6.6 or later
User Account	20	
Mobile Surveillance	Android, Blackberry, iPhone, Symbian & Windows Mobile	
<b>General</b>		
Built-in IR Illuminator	23EA LEDs, Effective up to 30m	
Micro SD Support	Optional	
Ingress Protection	IP66	
Unit Dimension (W × H × D)	Ø84 x 180(L) mm; Ø84 x 193(L) mm with Sunshield	
Unit Weight (Net)	940g	
Operation Temperature	-10 °C ~ 50 °C (14 °F ~ 122 °F)	
Relative Humidity	10% ~ 90%, Non-condensing	
Power Consumption & Input	System: 8W, Motorized Lens: +3.6W, DC12V / AC24V / PoE	
Certificate	CE, FCC, RoHS compliant	

Product specifications and availability are subject to change without notice. Certain product names mentioned herein may be trade names and / or registered trademarks of their companies.

DynaGuard™ CMS System Requirements (Recommended):

Windows 7 Professional, Intel® Core™ 17-2600 (3.4GHz) or faster, 4GB DDR3 RAM, GeForce GTS450 1GB PCI-E 16X Video Card, Gigabit LAN connection

\*For Windows Platform Only

**DYNACOLOR**  
always watching

**華輝** | 電 | 子 | 科 | 技 |  
**WECL** | ELECTRONICS SPECIALIST

A member of Sino Bright Group

華輝無線電行有限公司 Welfare Electronic Component Ltd.  
門市部 Retail :  
香港九龍深水埗鴨寮街201號明珠樓地下及一樓全層  
G/F & 1/F, Ming Chu Building, 201 Apliu Street, Sham Shui Po, Kln, Hong Kong  
Tel : (852) 3182 0688 Fax : (852) 3182 0600  
E-mail : cs@wecl.com.hk Hotline : (852) 3182 0888

Made in Taiwan

www.dynacolor.com.hk

V1\_20120830

☎ 客戶服務熱線:

(852) **3182 0888**

**WECLOnline.com**  
YOUR ELECTRONIC MEGASTORE

